

# PILATUS PC-6 GP/EP

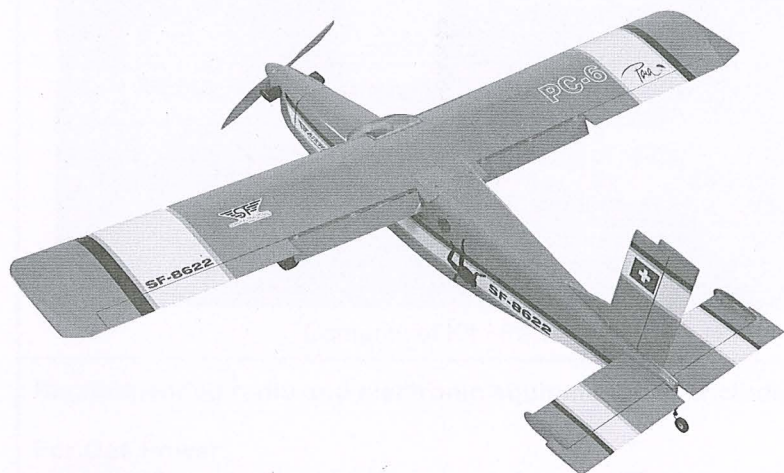

## SPECIFICATIONS

WING SPAN: 1640mm

LENGTH: 1246mm

WING AREA: 38.2 dm<sup>2</sup>

WEIGHT: 2200g

RADIO: 5ch

ENGINE: .40-.46(2C)

.46-.56(4C)

## EP

THRUST POWER: 2.5KGS AND UP

Recommended Battery: Li-Po 4-6 cells  
3000mAh and up

Recommended Motor: 600-900KV

Recommended ESC: 70-80A

## **Warning**

An RC aircraft is not a toy! If misused, it can cause serious bodily harm and damage to property. Fly only in open areas, following all instructions included with your radio.

Before beginning the assembly, remove each part from its bag for inspection. Closely inspect the fuselage, wing panels, rudder and stabilizer for damage. If you find any damaged or missing parts, contact the place of purchase.

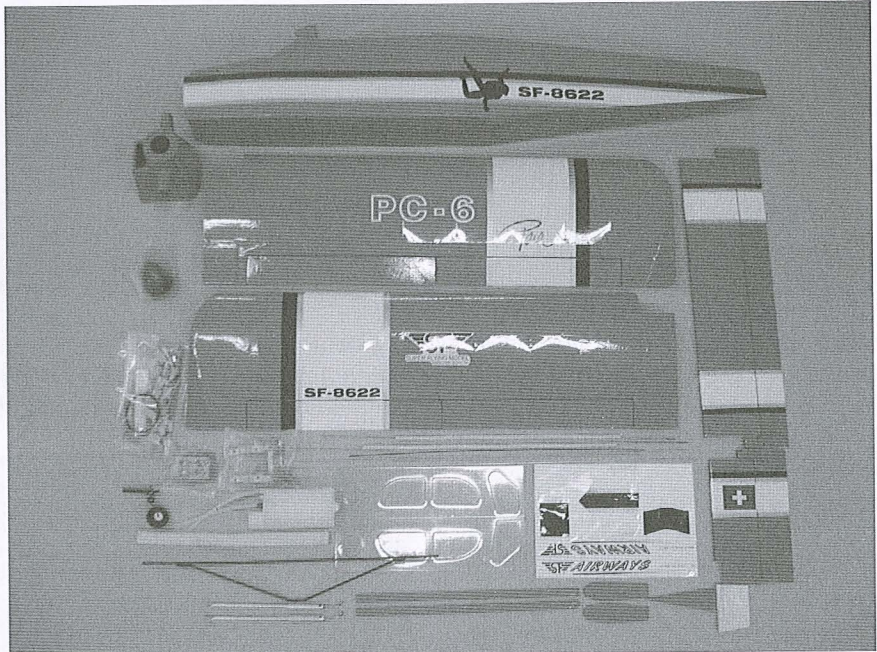

Contents of Kit / Parts Layout

**Recommended radio and electronic equipment (Not included in kit):**

**For Gas Power:**

5 channels radio x 1 piece / Receiver x 1 piece / 45g servo x 2 pieces  
 17g servo x 4 pieces (if use flap) / 30cm extension x 2 piece  
 60cm extension x 2 pieces / Y-harness x 2 pieces  
 Engine: .40-.46(2C) or .46-.56(4C) / Receiver battery 4.8V x 1 piece  
 Switch x 1 piece

**For Electric Power:**

600KV-900KV 700 type brushless motor / Thrust power: 2.5 KGS and up  
 Battery: Li-Po 4-6 cells 3000mAh and up / ESC: 70A-80A  
 Alu. adaptor (must match the shaft of the motor)

**Tools and suppliers needed (not included in kit):**

Phillips screws driver #0/#1 / 1.2/1.5/2.0mm drill / Curved scissors  
 Hex wrench 1.5/2.0mm / Hobby knife / Ruler / Pliers / Z-bender  
 Sanding Paper / Epoxy 5-10 minutes / Maker / CA glue / UHU foam glue  
 Cross wrench / Tape Reamer / Solder Iron and solder / Heat gun  
 Thread lock / Side Cutter



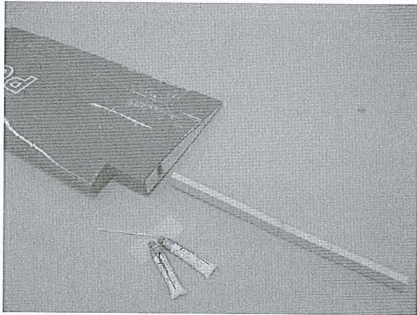

Try to insert the wing joiner into one of the wing panels. It should insert smoothly. If the fit is overly tight, it may be necessary to lightly sand the wing joiner.

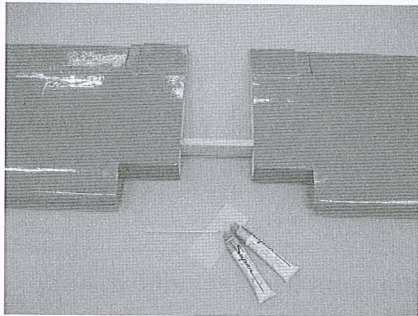

Spread the epoxy into the wing joiner cavity and wing joiner. Carefully slide the two wing halves together ensuring that they are accurately aligned. Firmly press the two halves together. There should not be any gap between the wing halves. Apply masking tape at the wing joint to hold the wing together securely while the epoxy cures.

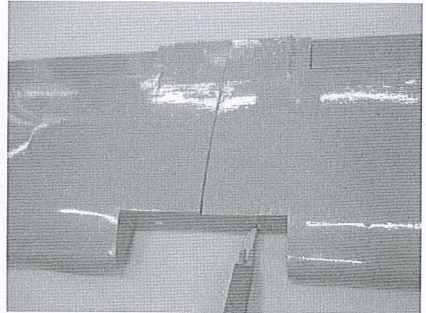

Locate the two pre-drilled wing dowel holes on the main wing. Using a sharp hobby knife, carefully cut the covering away from each of the holes.

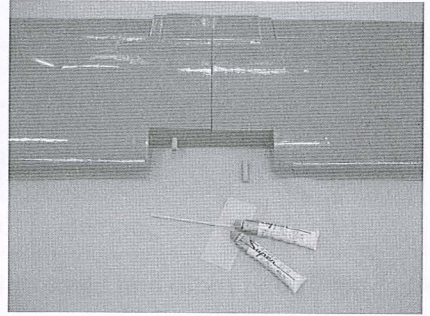

Take 2 pieces of 7mm dowels out of the hardware bag. Sand the end of the dowels and insert one of the dowels into each of the wing dowel holes.

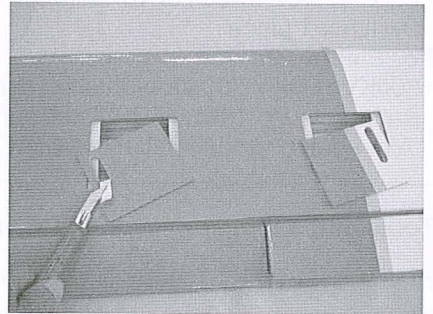

Turn the wing upside down and find the servo trays for the aileron and flap. Using a sharp hobby knife,

carefully remove the covering over the exit hold for the servo arm.

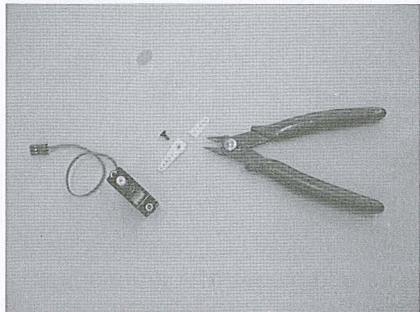

Place a 17g servo on the working table. Use side cutter to remove the extra part of the servo arm as shown.

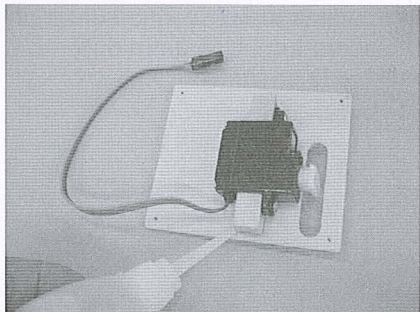

Turn on the radio. Connect the servo with battery and servo plug. Set the servo at neutral position. Secure the servo arm on the servo with the screws supplied with the servo. Take 2 pieces of 12x12x20mm block out of the hardware bag. Place the servo on the servo tray with the servo arm facing the center of exit hole. Spread some glue on one side of both block and place the blocks on two sides of servo for securing the servo on the servo tray.

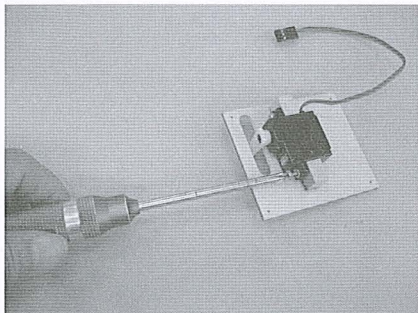

Secure the servo on the servo tray with the screws supplied with the servo.

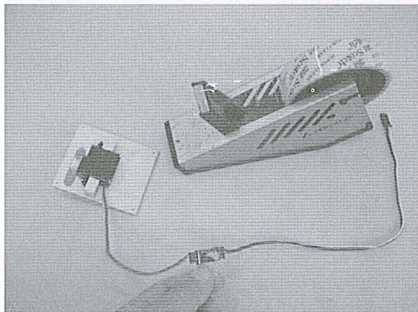

Connect the servo plug with 30cm extension. Apply some tape on the jointing place for avoiding losing off.

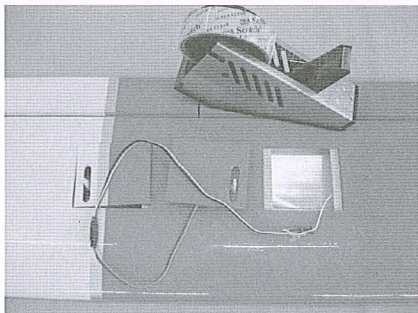



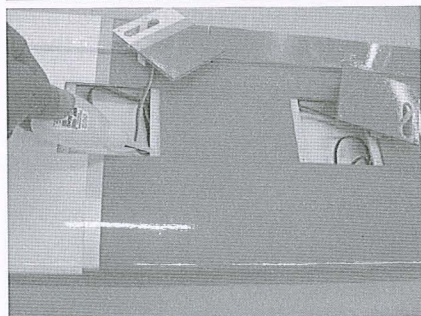
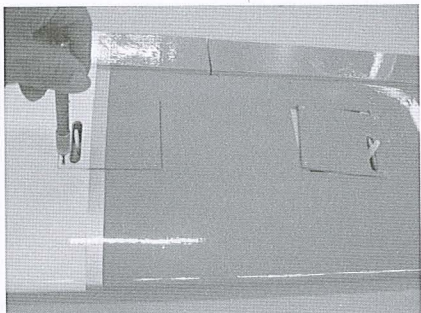

Try to a cotton line inside the main wing. Carefully tie the cotton line onto the extension. Pull the beginning of the cotton line, so it will bring the extension through the main wing.

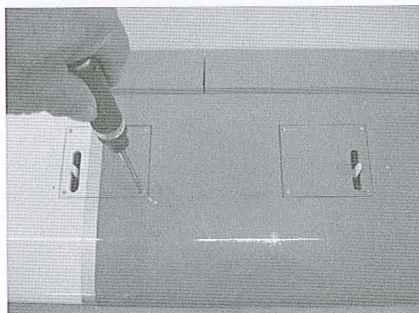

Use 1.5mm driller to drill holes on the servo tray. Drop some instant glue into the holes. Take 4 pieces of 2.8mm tapping screws and secure the servo tray in position.

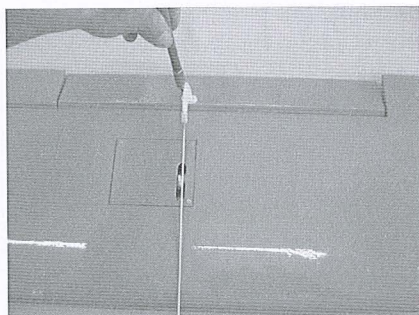

Take one pieces of rod and insert through 5mm long silicone tube. Screw in the clip and connect with control horn temporary. Place the control horn on the leading edge of flap. Adjust the rod to the center of the servo arm. Use 2mm driller to drill holes on the control horn.

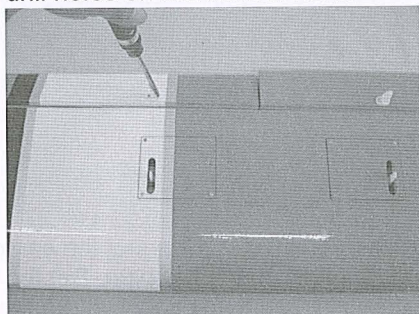

Use 2x20mm to secure the control horn and plate in place.

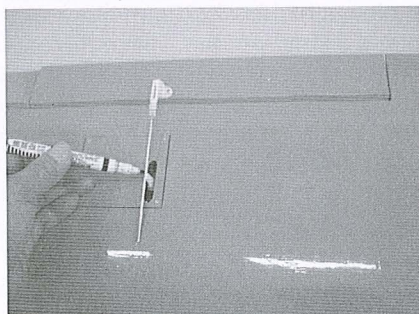

Connect the clip with control horn. Use marker to mark the position where rod contact with servo arm.

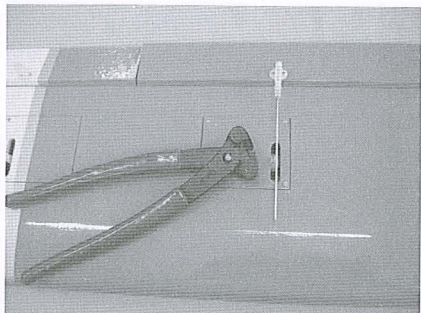

Use Z-bender to make a Z bend on the marked position. Connect the servo with battery, set the servo at neutral position. Connect the Z end with servo arm and another end with control horn. Remove the silicone tube on the clip.

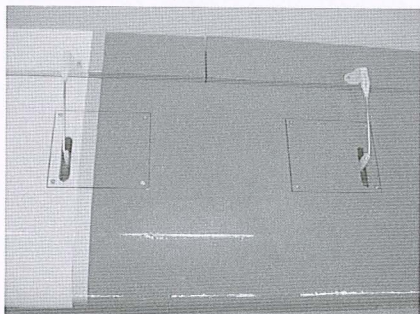

Repeat the same procedure for the aileron. Please note the exits for aileron servos are on the outer sides.

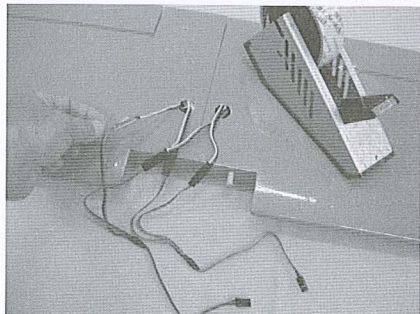

Connect the plugs of flap and aileron servos with Y cables. Apply color tape as a mark.

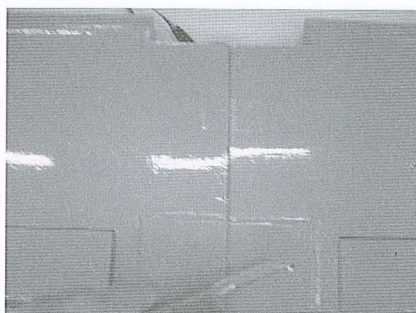

Try to find two pre-drilled holes on the rear edge of main wing. These holes are for the main wing bolts. Use a sharp hobby knife carefully to cut off the covering over the holes.

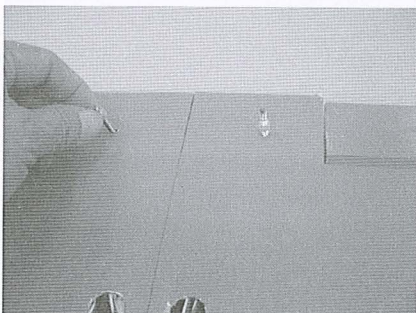

Insert the 4x40mm main wing bolts and washers through the holes. Insert 5mm silicone to the screws for avoiding losing off.

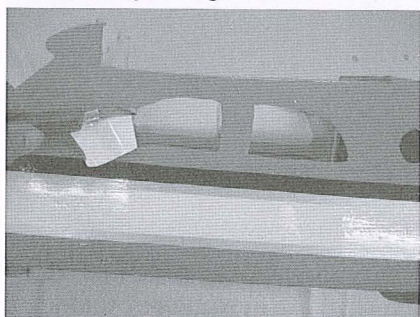

Use a sharp hobby knife carefully cut out the covering over the windows. Please keep 7mm covering on the edges.



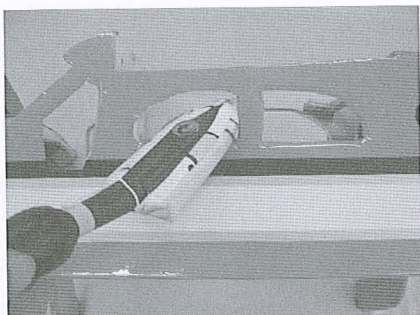

Adjust the temperature of the sealing iron to 140 degree and iron the covering on the windows edges.

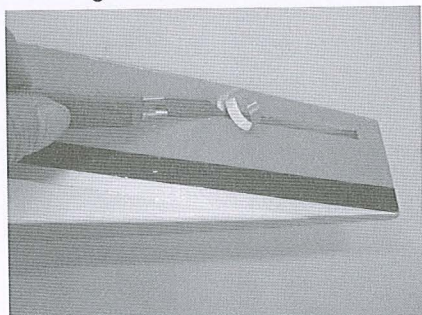

Use a sharp hobby knife to remove the covering over the slot for the elevator and the wood on the tail edge.

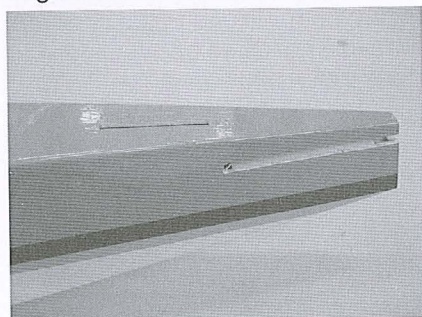

Use a sharp hobby knife to remove the covering over the slot for the rudder.

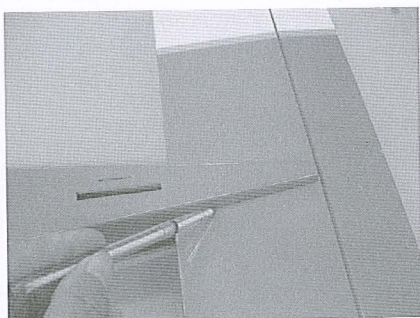

Place the elevator on the working table. Use ruler to measure the center position. Try to install the elevator into the tail slot and set up the center position to the center of the fuselage. When satisfy the location, use pen to mark the outline of the fuselage on the elevator.

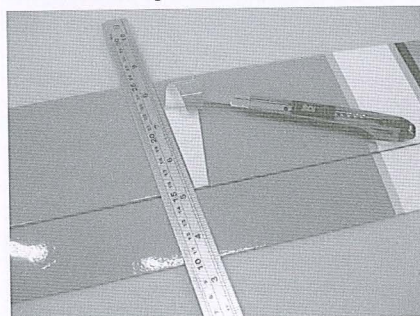

Use a sharp hobby knife to remove the elevator covering inside the marking area. Please note don't cut into the wood.

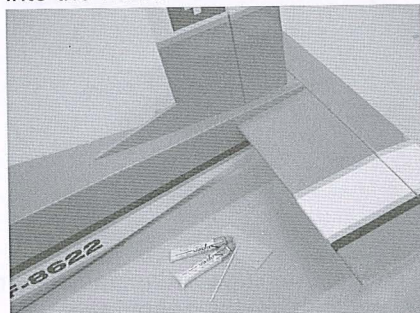

Mix some AB glue to secure the fin on the rudder.

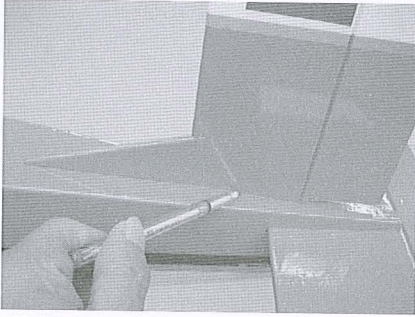

Try to install the vertical into the vertical slot on the fuselage. When satisfy the location, use pen to mark the outline of the fuselage on the rudder.

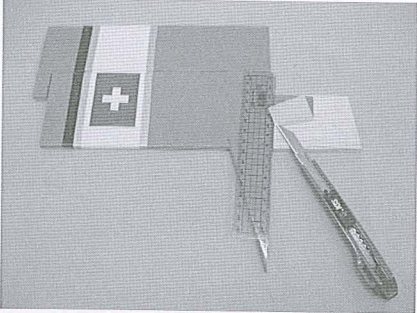

Use a sharp hobby knife to remove the covering inside the marking area.

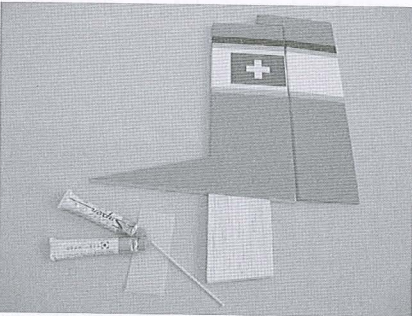

Mix some AB glue to secure the vertical on the fuselage.



Try to install the main wing onto the fuselage. Please note the distance of both wing tips to the tail wing must be the same ( $A=B$ ). Spread some glue on the bottom of the rudder and install onto the fuselage. Please note the rudder must be perpendicular to the elevator. Apply some tapes on the rudder for holding the rudder in place before the glue dried.

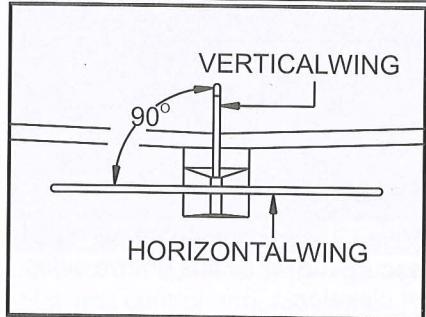
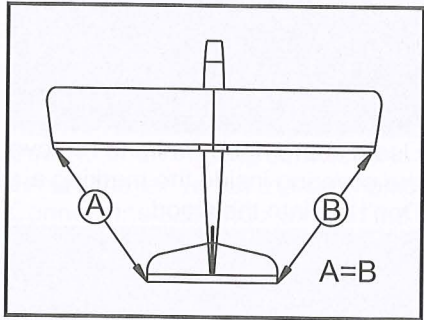

Assemble the horizontal and vertical wing on the fuselage and use epoxy



to secure them in place.

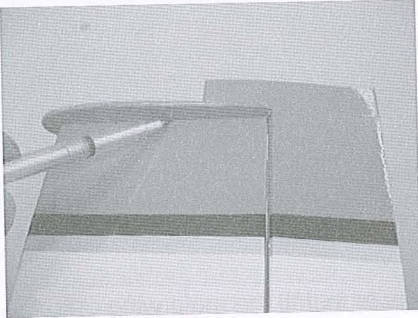

Try to locate the small fins onto the elevator. When satisfy the location, use pen to mark the contacting area on the fins.

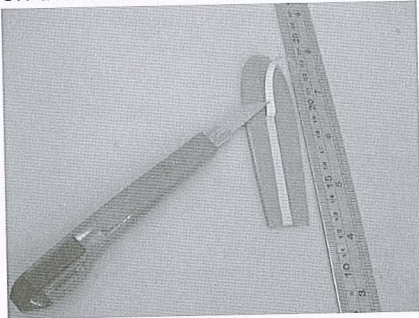

Use a sharp hobby knife to remove the covering inside the marking area. Don't cut into the wood.



Mixed a small amount of AB glue to secure the small fins on two sides of elevator.

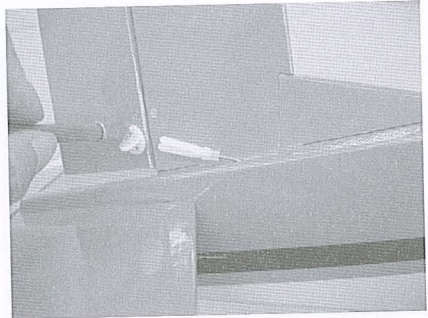

Try to place a control horn on the rudder. This control horn must face the rod for the rudder. When satisfy the location. Use 2mm driller to drill the holes for securing the control horn.

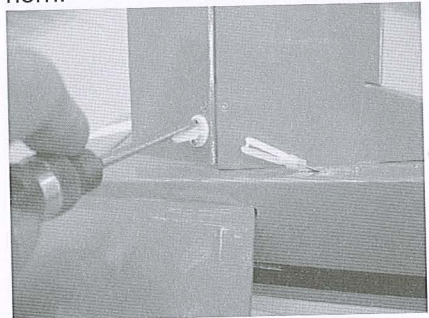

Use 2x20mm screws to secure the control horn and plate in place.

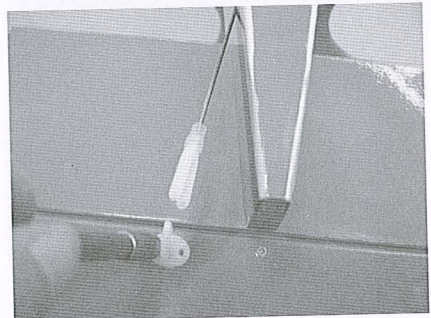

Place a control horn on the elevator. This control horn must face the elevator rod. When satisfy the location. Use 2mm driller to drill the holes for securing the control horn.

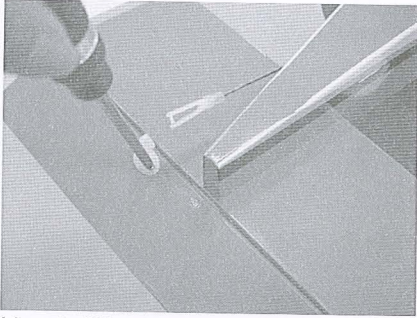

Use 2x20mm screws to secure the control horn and plate on the elevator.

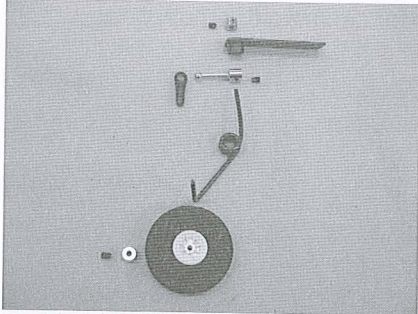

Assembling the tail wheel set as the picture shown. Insert the bended end of the tail wire into the wheel. Place a collar onto the wheel and secure the collar with 3x4mm hex-screw. Insert the other end through the ball-end linker, control arm. Secure the control arm with 3x4mm hex-screw. Place the tail wheel mount on the top and secure it in place with 2mm collar and 3x4mm hex-screw.

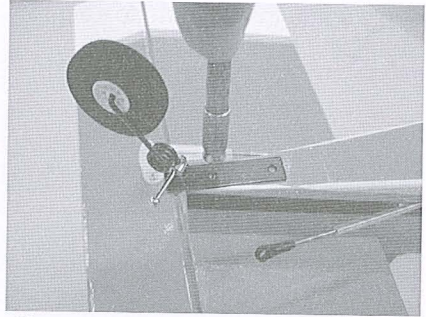

Place the tail wheel assembling on the bottom of tail. There is 1mm space between the collar and the tail end. Use 2mm driller to drill the holes to securing the tail wheel assembling.

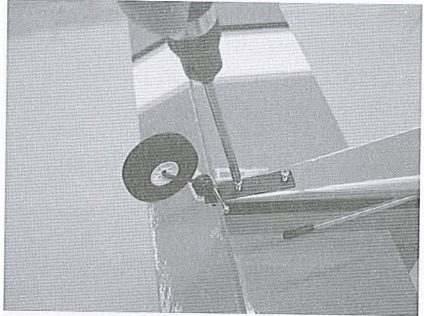

Use 3x10mm tapping screws to secure the tail wheel mount in place. Connect the ball-end liker with the rudder rod.

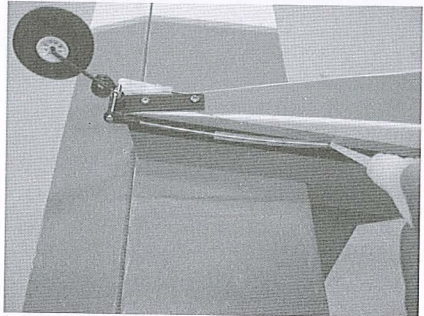

Connect the ball-end of the rod with tail wheel control arm. Move the outer tubing of the rod and keep 25mm space from the rod end and



apply some instant glue to secure the tubing on the fuselage.

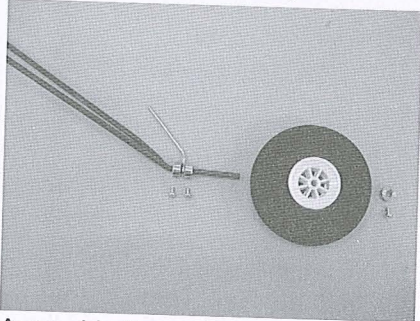

Assemble the main gear assembling as picture shown. Insert one piece of 3x6mm collar and secure in place with 3x6mm hex-screw. Place the anti-vibration strut onto the collar and secure the strut in place with collar and 3x6mm hex-screw. Insert the wheel to the main gear wire and secure it in place with collar and 3x6mm hex-screw.

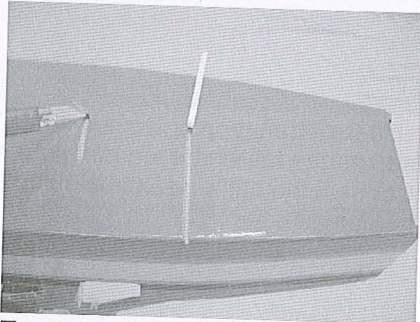

Try to find the pre-served two slots on the bottom of the fuselage. Use a sharp hobby knife to remove the covering over the slots. The short slot must be the same length as the second (short) main gear wire.

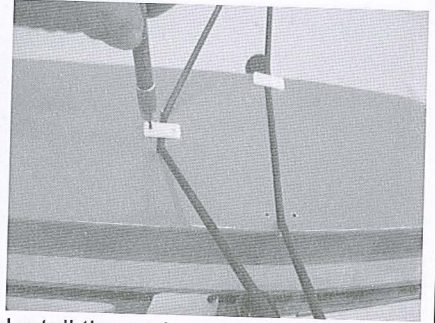

Install the main gear assembling. Place the fixing plates over the main gear. Use 2mm driller to drill holes for securing the main gear.

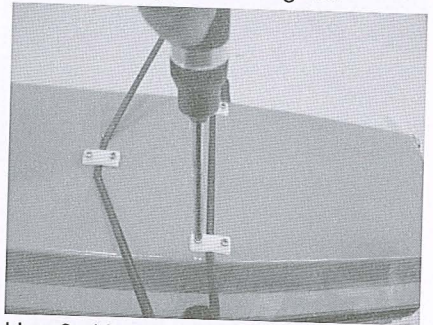

Use 3x12mm tapping screws to secure the main gear in place.

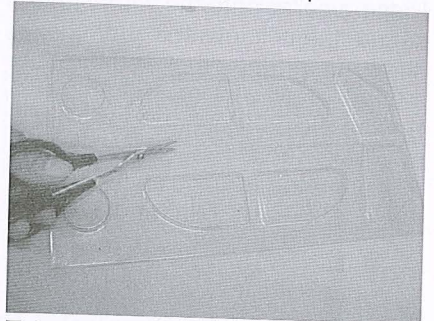

Take the molding plastic parts out of the hardware bag. Use the scissors to cut it from the center line as picture shown.

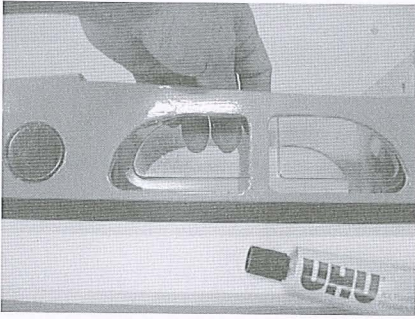

Spread UHU glue over the edges of the plastic side windows and glue the side windows in place. Apply tapes over the edges to hold the windows in place and wait for the glue to dry completely.

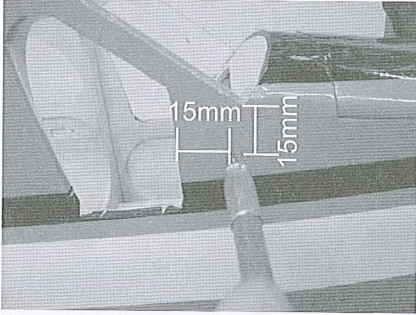

Please refer to the picture and mark a location on the head of fuselage. Use 1.5mm driller to drill a hole on the marked location.

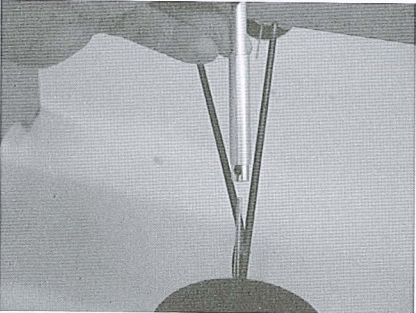

Insert the anti-vibration strut into the anti-vibration tube and secure it with 4x4mm screws. Don't screw too tight.

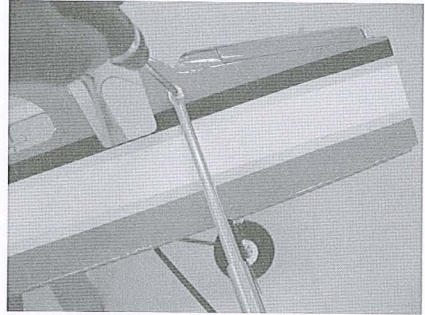

Secure the anti-vibration tube on the fuselage with 2.6x12mm tapping screws. Now, you can screw the 4x4mm tight right now.

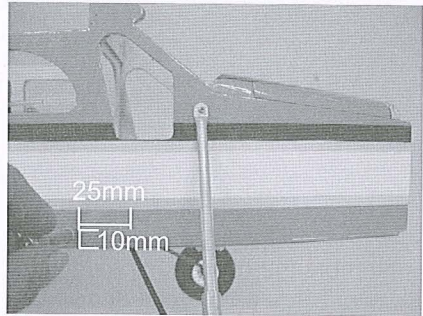

Mark a position on the fuselage as the picture shown. Drill a 1.2mm hole on the marked position.

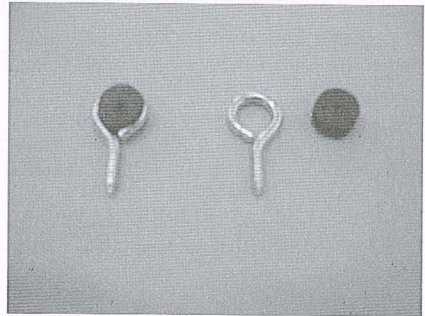

Take 4 pieces of eye-screws and rubber eyelets out of the hardware bag. Stuff the eyelets into the eye-screws.



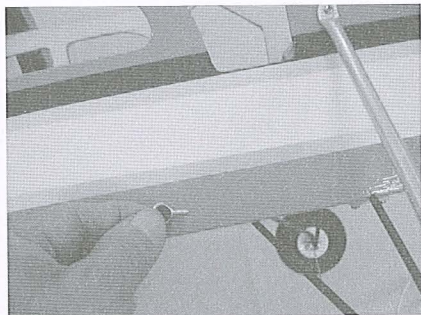

Screw the eye-screw into the drilled hole.

#### FOR THE EP VERSION

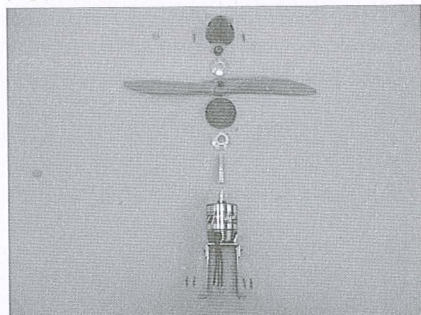

Assemble the power unit as picture shown. Secure 2 pieces of motor side mounts and U mount with 3x8mm screws, washers and nuts. Drop some threadlock on the motor screws and secure the motor on the U mount. Place the mount onto the firewall. Try to match the screw holes on the motor mount with the pre-drilled 1mm holes on the firewall. Secure the motor mount in place with 3x10mm tapping screws. (Please note: when connect with ESC, please refer to the ESC manual.)

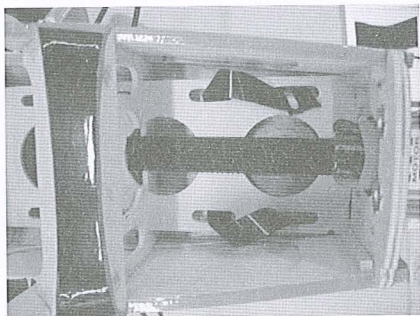

Insert the hook and loop strap through the holes on the two sides of the battery tray. Apply the strap between the battery and battery tray.

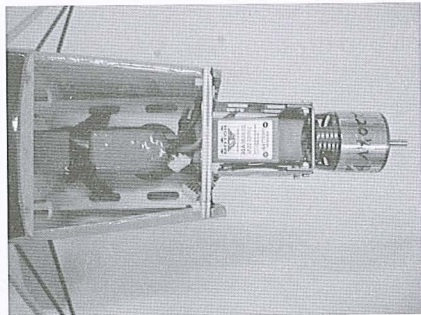

Connect the ESC with the receiver throttle. Secure the battery on the battery tray (via the hook and look strap). Connect with battery and switch the power on for checking the moving direction of the motor and ESC function.

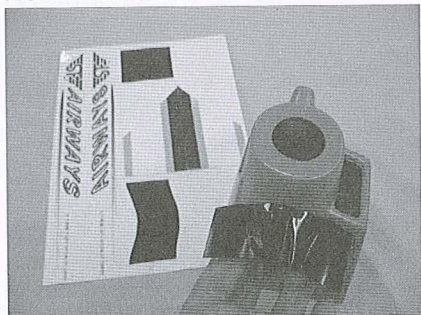

Take the cowling and decorative sticker out of the hardware bag.

Apply the muffler sticker over the outside of the muffler.



Install the cowling on the fuselage. Assemble the spinner with propeller and aluminum adaptor. Please leave 1.5mm space between the spinner mount and the cowling. It may be necessary to trim the cowling shorter if it is too long for your operation. When satisfy the installing, use 1.2mm driller to drill 2 holes on both sides of cowling.

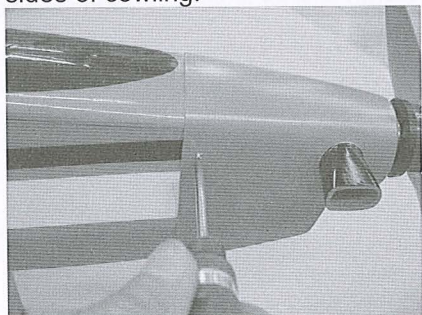

Use 2x8mm tapping screws to secure the cowling in place.

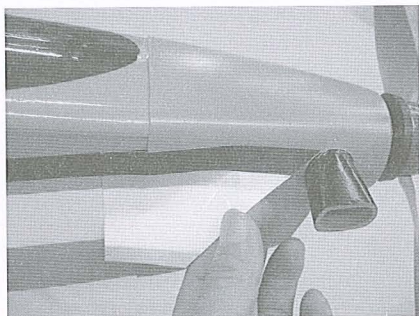

Apply the decorative sticker on both sides of cowling.

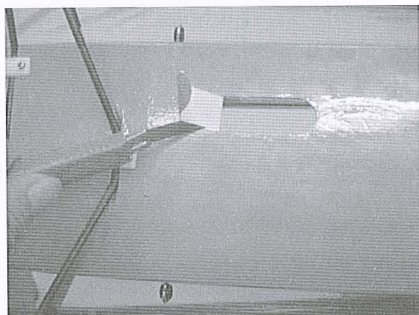

Use a sharp hobby knife to cut the vent on the bottom of the fuselage.



Apply the SF AIRWAYS decorative sticker on the fuselage.



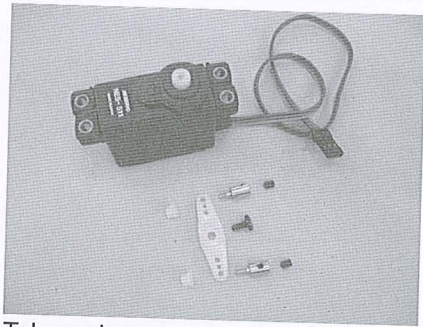

Take rod connectors, plastic nuts and 3x4mm hex-screws out of the hardware bag and place on the working table. Place the servo and servo arm that you purchased on the table. Drill the outer hold in a servo arm using a 2mm drill bit. Attach the rod connector to the servo arm using 3x4mm screw and nut. Don't screw too tight and make sure the servo arm can move freely.

Set the servo at the neutral position and install the servo on the servo mount. Secure the servo onto the servo mount with the screws supplied with servo.

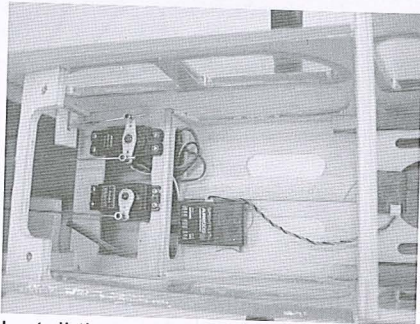

Install the servo mount inside the fuselage and secure in place with epoxy.

Connect the elevator rod with the center servo. Connect the first servo with rudder rod and tail wheel gear. (The last 17g servo is for connecting the engine throttle. The picture is for

EP version.) Connect the servo with receiver and test the operation and use 1.5mm hex wrench to secure the 3x4mm hex-screws. Move the silicone tubing over the connector for avoiding losing off during flying.

#### FOR GP FLYING

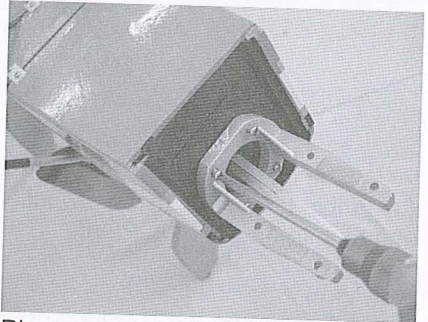

Place engine mount on the firewall and match the holes of the engine mount to the 4mm screw holes on the firewall. Secure the engine mount in place with 4x20mm screws.

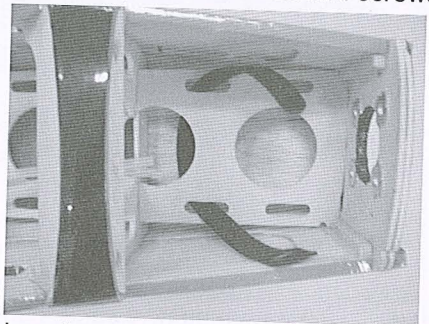

Insert a piece of hook and loop strap through the battery tray.

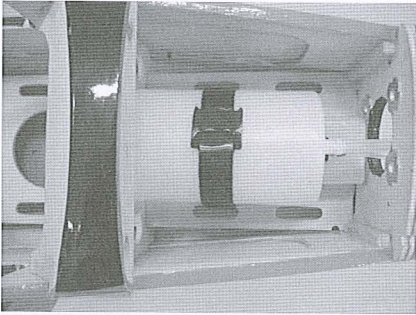

Place the fuel tank after the firewall and use hook and loop strap to secure the fuel tank in place.

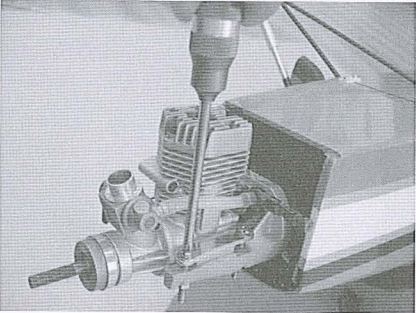

Install the engine on the engine mount and secure it in place with engine mount plates, 4x30mm screws and 4mm nuts.

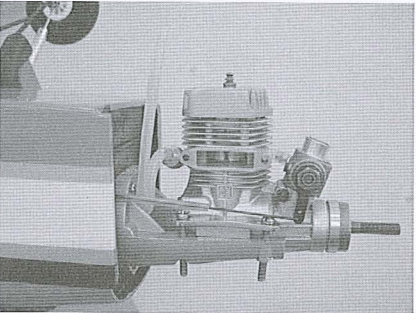

Use Z bender and make a Z bend on the throttle rod and connect with throttle control arm. Connect the fuel tubing which attached with clunk with the carburetor.

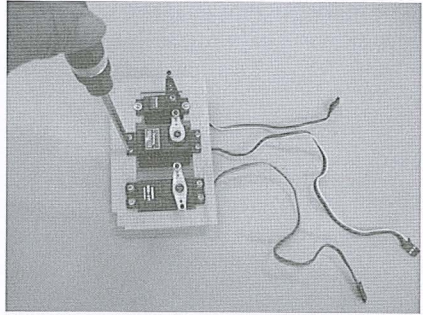

Secure the servos on the servo mount with the screws supplied with servos. The servos you needed is one piece of 17g, 2 pieces of 45g.

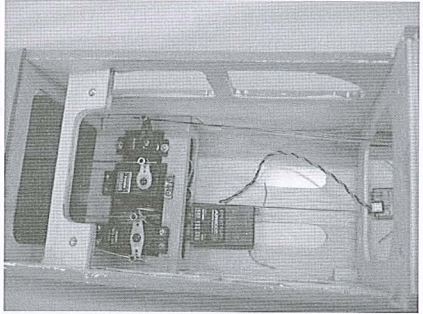

The first servo is 17g will connect with throttle rod. The second servo with connect with elevator rod. The third servo with connect with rudder rod and tail gear.

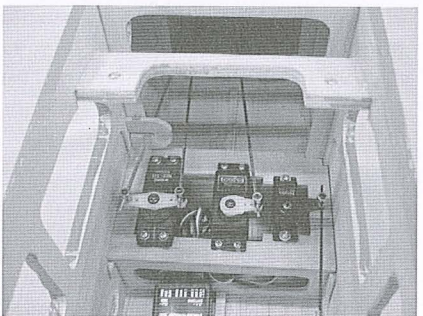

Keep 20mm space between the end of outer tubing and rudder rod connector. Secure the out tubing on the side of fuselage with instant glue



and a U planking.



Keep 20mm space between throttle outer tubing and elevator rod. Secure the out tubing on the side of fuselage with instant glue and a U planking.

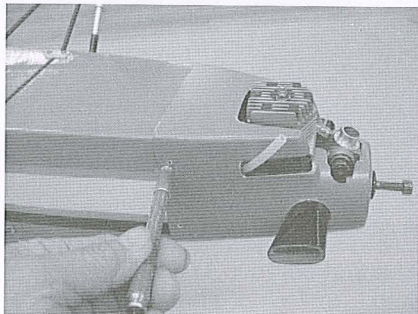

Apply the muffler sticker around the plastic muffler on the cowling. Try to fit the cowling on the fuselage. Adjust the location of cowling. When satisfy the location, use a hobby scissors to open the exits for muffler and carburetor. Use 1.5mm drill bit to drill two holes on two sides of cowling.

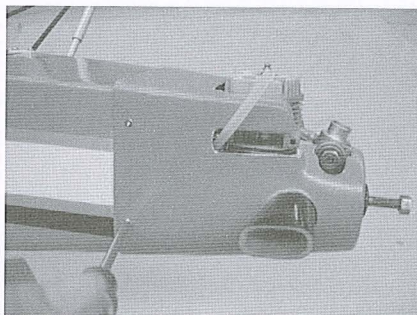

Use 2x8mm tapping screws to secure the cowling in place.

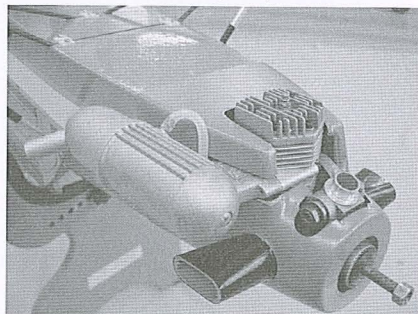

Install the muffler and contact the fuel tube.



Install the main shaft of engine into the spinner mount. Place the APC 11x6 propeller (or propeller for .46 engine.). Secure it in place with washer, nut. Place the spinner on the top and secure it in place with 3x12mm tapping screws.

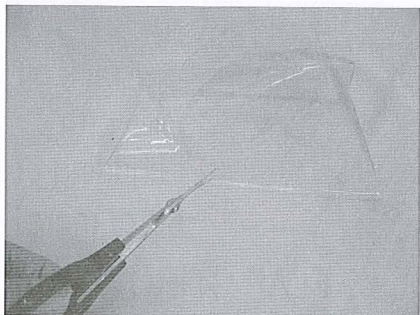

Use hobby scissors to trim the canopy.

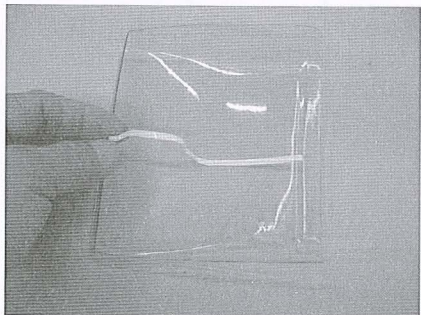

Apply a white decorative sticker on the center part inside the canopy.

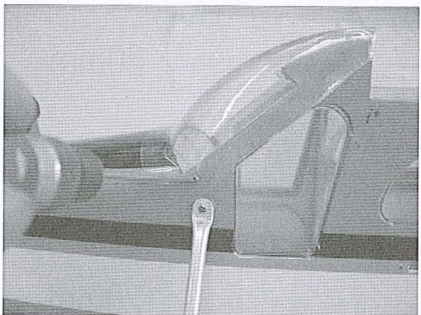

Try to fit the canopy on the fuselage. When satisfy the location, secure it in place with 2,8mm tapping screws.

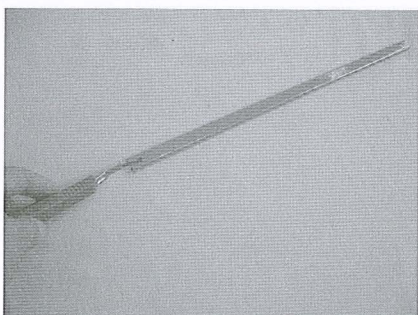

Take the main wing strut on the working table. Use a hobby knife to cut off the covering over the slot.

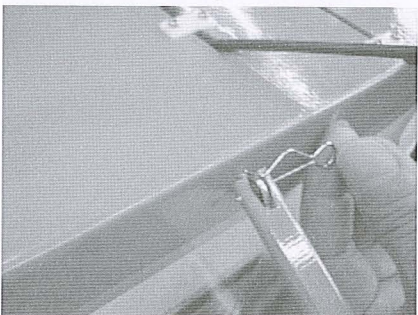

Install the main wing onto the fuselage. Connect one end of the main wing strut with eye screw on the fuselage and secure with R pin.

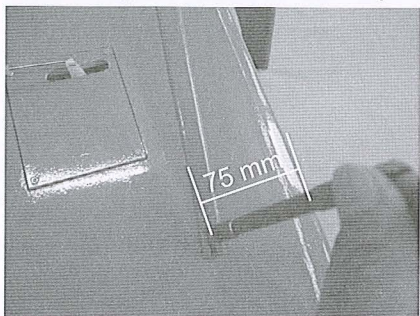

Place the other end on the main wing around 75mm back from the leading edge. Use 1.5mm drill bit to drill hole.



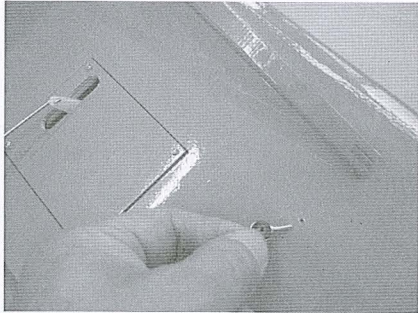

Screw in one eye screw on the hole.

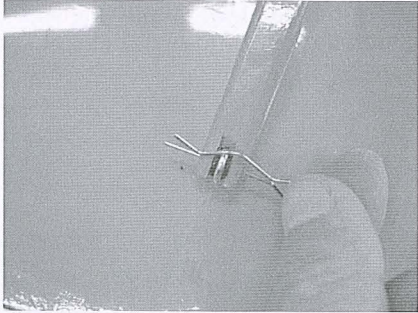

Connect the end of wing strut with eye screw on the main wing and secure with R pin.

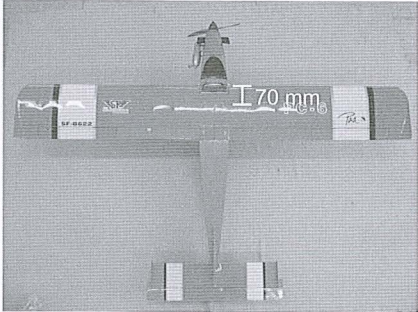

The recommended Center of Gravity location is 70mm back from the leading edge.

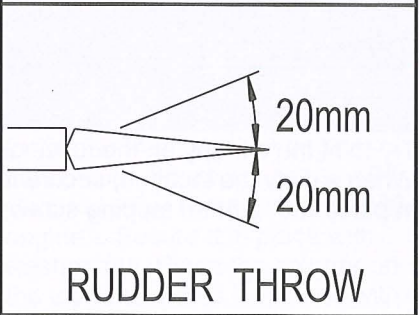
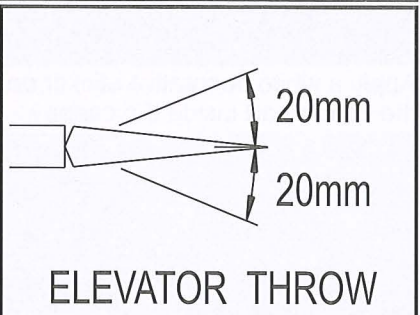
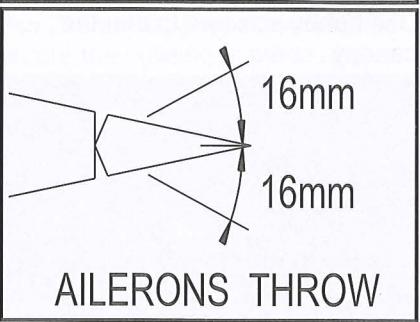
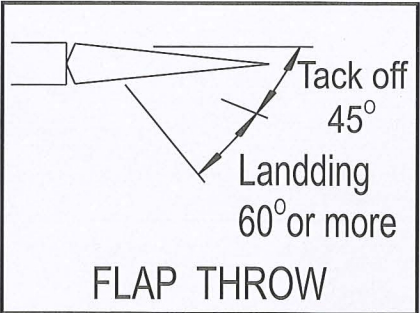

## FOR THE GP VERSION

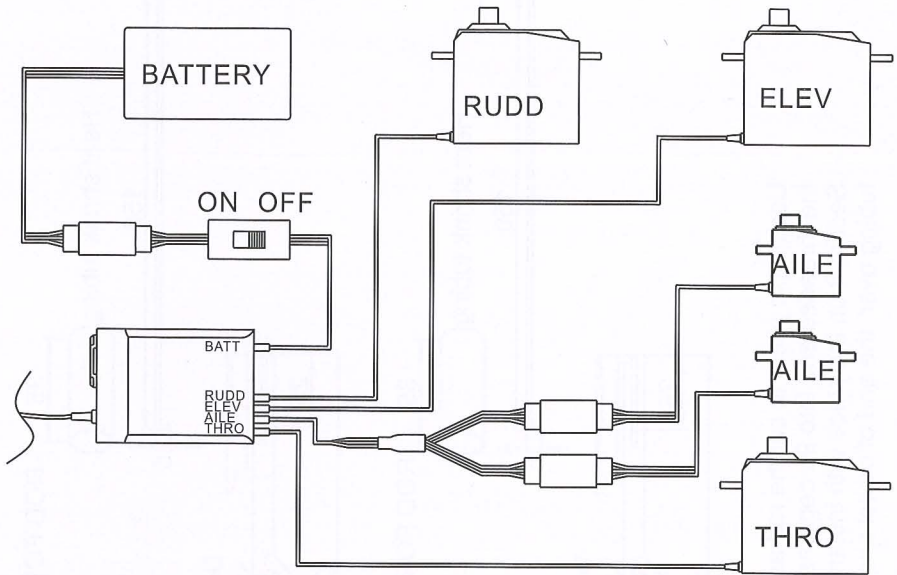

## FOR THE EP VERSION

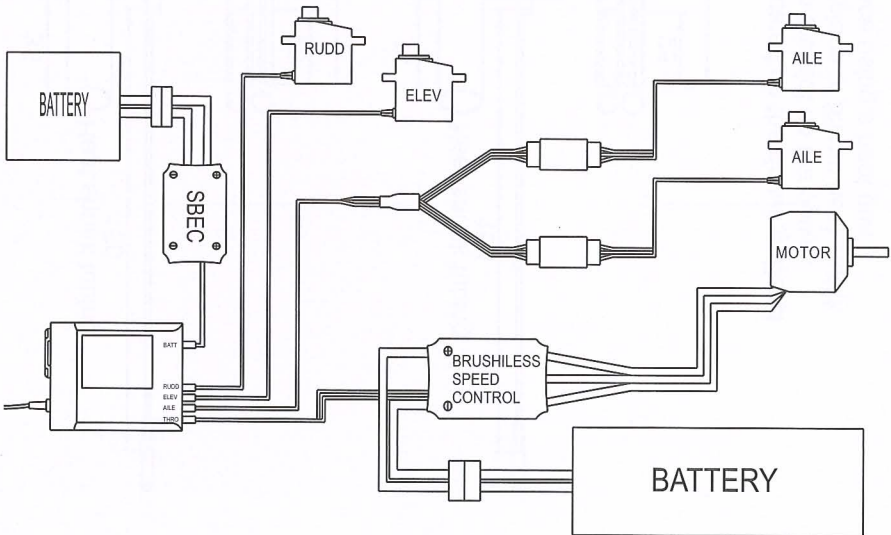



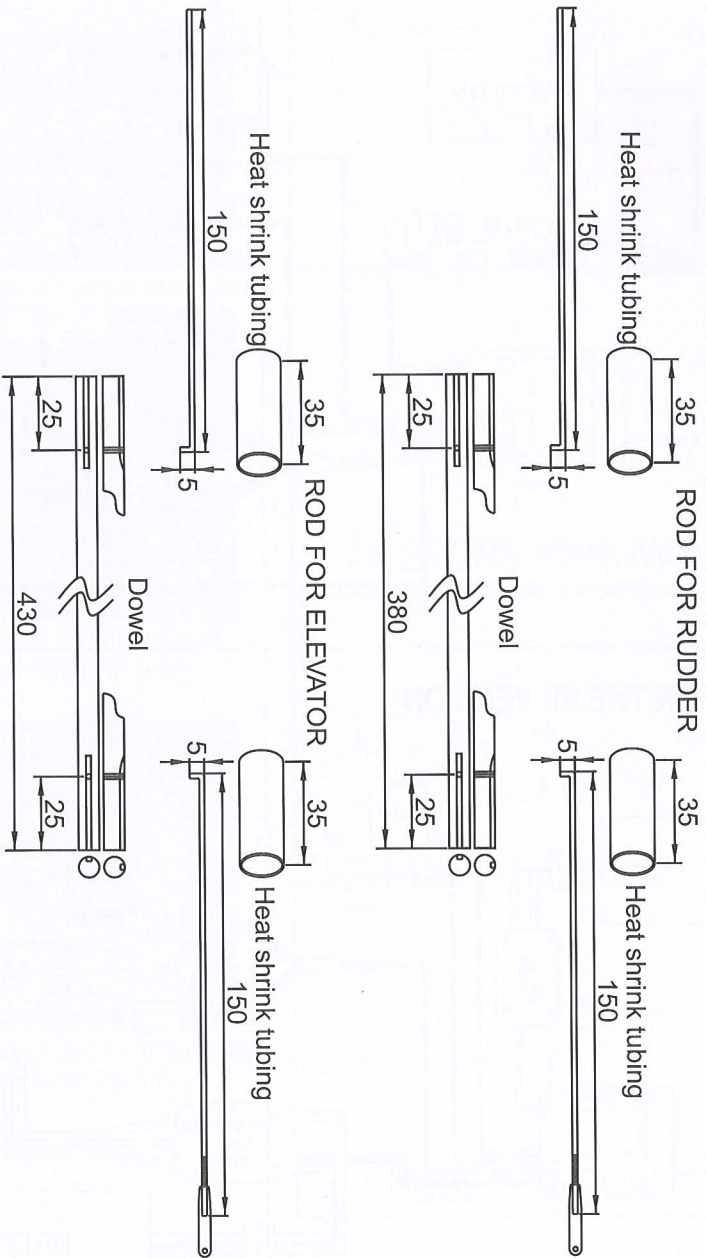

Use nipple pliers to cut the rod as the sizes indicated on the drawing. Bend the threaded end into 90 degrees and insert into the slot on the dowel. Secure it on the place with instant glue. Slide a piece of 35mm heat shrink tubing over the end of dowel and shrink it in place using a heat gun.